

**SPECIFICHE TECNICHE** *Technical specification*

|  |   |
|--|---|
| <b>Portata massima al gancio principale</b><br><i>Main hook max capacity</i> | 10000 kg  |
| <b>Raggio di sterzata</b><br><i>Steering radius</i>                          | 3260 mm   |
| <b>Peso gru (circa)</b><br><i>Weight (about)</i>                             | 10000 kg  |
| <b>Braccio telescopico</b><br><i>Telescopic boom</i>                         | Completamente idraulico, braccio base, 2 prolungh. <i>Full hydraulic, 3 sections, box boom</i>  |
| <b>Tipo di sterzata</b><br><i>Steering</i>                                   | Idraulica su ponte posteriore <i>Rear hydraulic steering</i>  |
| <b>Gomme</b><br><i>Tyres</i>   | 2 SOLID REAR 23 x 9 - 10 , 4 SOLID FRONT 250 - 15   |
| <b>Tipo di trazione</b><br><i>Drive system</i>                               | Anteriore bimotore (2 motori) con contro rotazione comandata da controllo elettronico AC (corrente alternata) <i>Front with 2 motors on front axles, with counter rotation operated by high performance AC electronic controllers</i>   |
| <b>Freni</b><br><i>Brakes</i>  | A disco su asse anteriore (a richiesta su asse posteriore) <i>Disk brakes on front axle (on demand on rear axle)</i>  |
| <b>Versione elettrica</b><br><i>Electrical version</i>                       | Standard AC (corrente alternata) <i>Standard AC</i>   |
| <b>Motori trazione</b><br><i>Drive motors</i>                                | 11,3 kW - AC x 2 MOTORS   |
| <b>Batterie</b><br><i>Power source</i>                                       | 80V 640 Ah  |
| <b>Versione Diesel - idrostatica</b><br><i>Diesel-hydrostatic version</i>    | Su richiesta <i>On demand</i>   |
| <b>Equipaggiamento di serie</b><br><i>Standard equipment</i>                 | Limitatore di carico con display, distributore idraulico proporzionale controllato da joystick, allarme di retromarcia, sedile con sensore uomo presente e cinture di sicurezza <i>Digital safe load indicator with display, joystick controlled proportional distributor, reversing alarm, seat sensor and seatbelt, worklight</i> |
| <b>Equipaggiamento facoltativo</b><br><i>Optional equipment</i>              | Gancio supplementare, falconcini, argano, forche, cestello (su versione Multis), gomme antitraccia, radiocomando, altri su richiesta. <i>Searcher hook, jib, forks, operator platform (Multis), low marking tyres, radio remote control. Other equipment available</i>  |

Le gru Galizia sono realizzate in conformità alla Direttiva Macchine. La Galizia s.n.c. si riserva il diritto di modificare questi dati senza nessun preavviso.  
Galizia cranes are manufactured in compliance with CE regulation. The company Galizia s.n.c. reserves the right to change the present technical data without previous notice.



gru semovente elettrica  
electric pick and carry crane



trazione anteriore bimotore con contro rotazione e sterzata totale

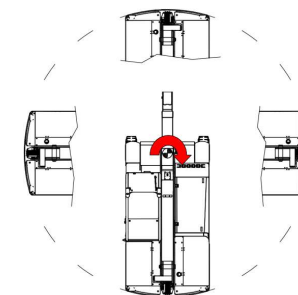

front wheel drive with 2 motors and counter rotation - total steering

### Caratteristiche uniche della GF100

- capacità di sollevare, spostare e posizionare carichi di grande peso senza l'ausilio di stabilizzatori;
- compattezza e raggio di sterzata minimo;
- trazione anteriore bimotores, che avviene per mezzo di due motori elettrici in grado di effettuare la contro-rotazione mediante un differenziale elettronico;
- azionamenti graduali e precisi del braccio, ottenuti tramite distributore proporzionale comandato da JOYSTICK, che permette anche i movimenti simultanei;
- sicurezza e affidabilità;
- braccio in posizione ribassata per consentire:
  - ampia visibilità da posto guida;
  - possibilità di accedere sia con il gancio sia con gli attrezzi all'interno di furgoni, camion centinati e vani ribassati;
- **tipologia di appoggio a 4 ruote, ma raggio di sterzata simile a quello di una gru semovente a 3 ruote, grazie all'abbinamento tra lo speciale ponte sterzante posteriore e alla trazione bimotores anteriore;**
- 2 motori elettrici AC per la trazione e relativi controlli elettronici AC (corrente alternata);
- 1 motore elettrico per il sollevamento e relativo controllo elettronico
- cabina dal design moderno ed innovativo



- the power to lift, move and place very heavy loads with no outriggers;
- compactness and minimum steering radius;
- high precision and gradualness of the movements, guaranteed by up-to-date electronic controls with programmable microprocessors;
- front wheel drive twin motor obtained through 2 electrical motors, that can perform counter rotation through an electronic differential gear;
- gradual and exact driving of the boom, obtained through a proportional distributor operated by a joystick, allowing also simultaneous movements;
- safety and reliability;
- lowered boom so to allow
  - wide view from the driving seat;
  - access to the inside of vans or trucks, by both hook and jibs;
- **support on 4 wheels, while steering like a 3 wheels pick and carry crane, thanks to the coupling of the special rear steering bridge and the front 2 motors drive system;**
- 2 AC electric motors for drive and relevant electronic controls;
- 1 electric motor for lifting and relevant electronic controls;
- ergonomic and comfortable body, with modern and innovative design;

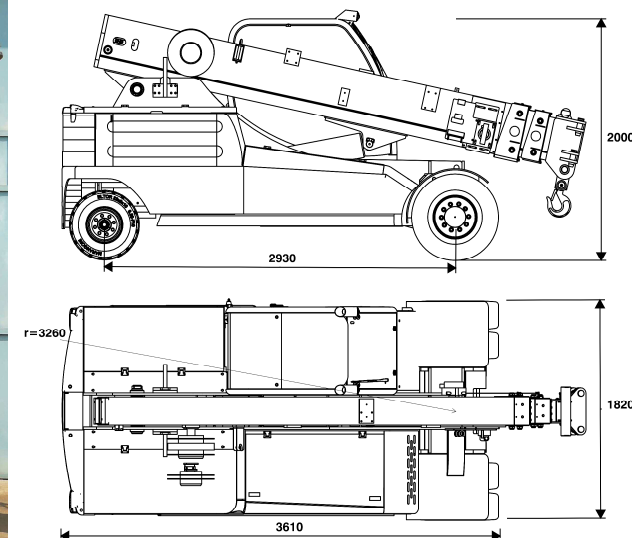
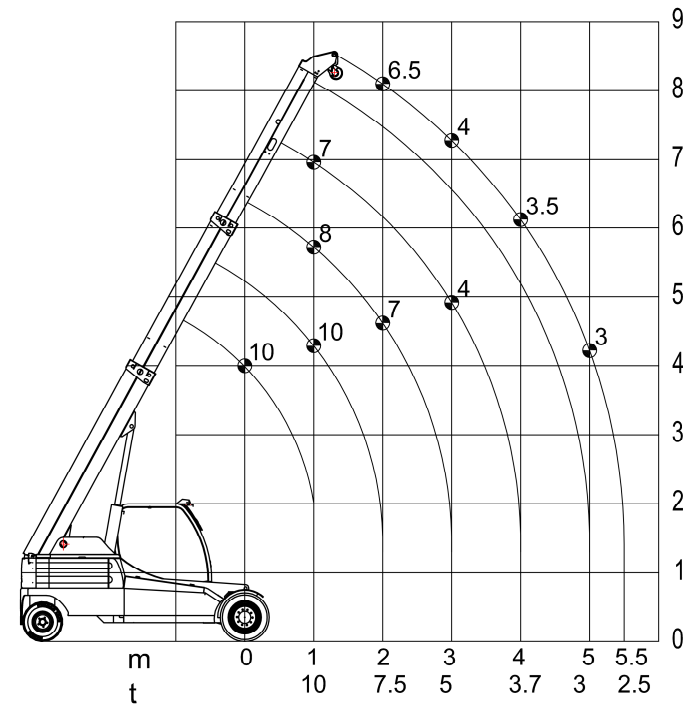

**DIAGRAMMA PORTATE GF100  
BRACCIO BASE MAX 10000 kg  
MODO OPERATIVO 0 - M0**

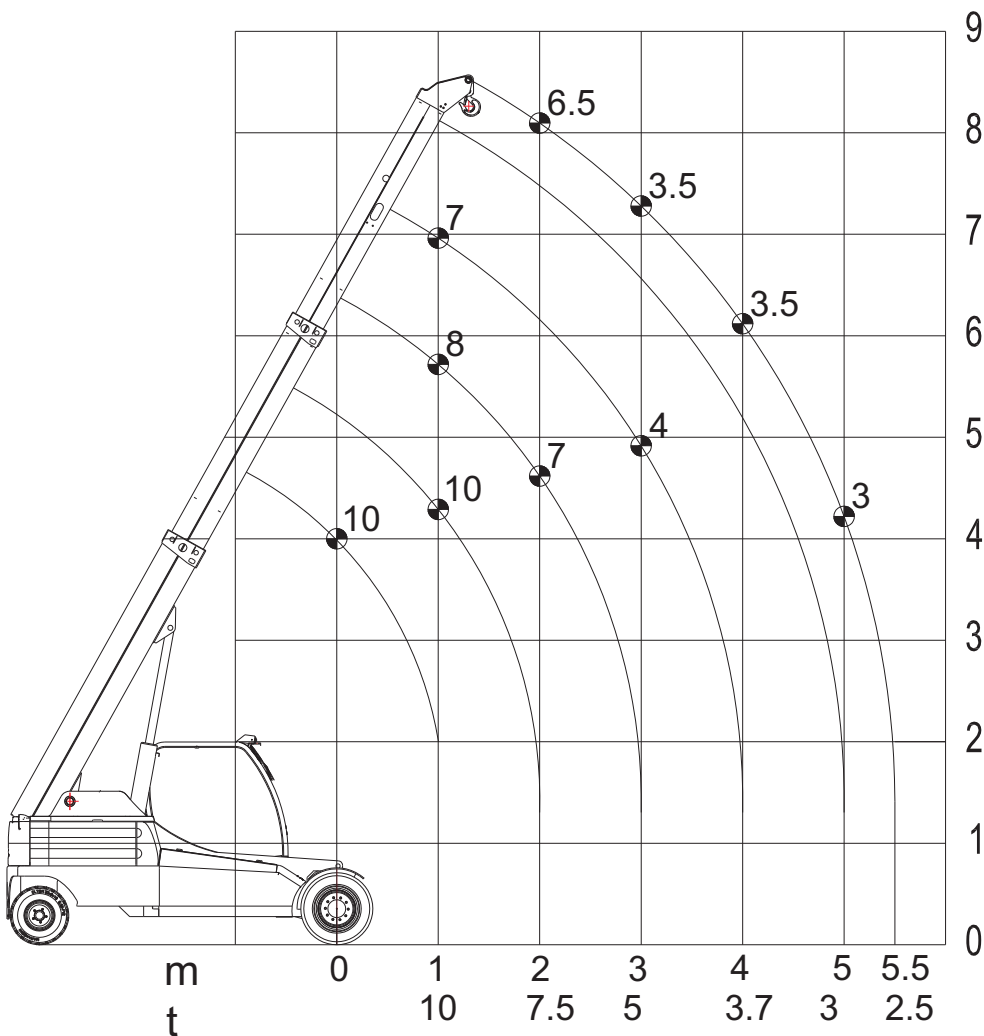

**DIAGRAMMA PORTATE GF100  
FALCONCINO CHIUSO MAX 6.500 kg  
MODO OPERATIVO 1 - M1**

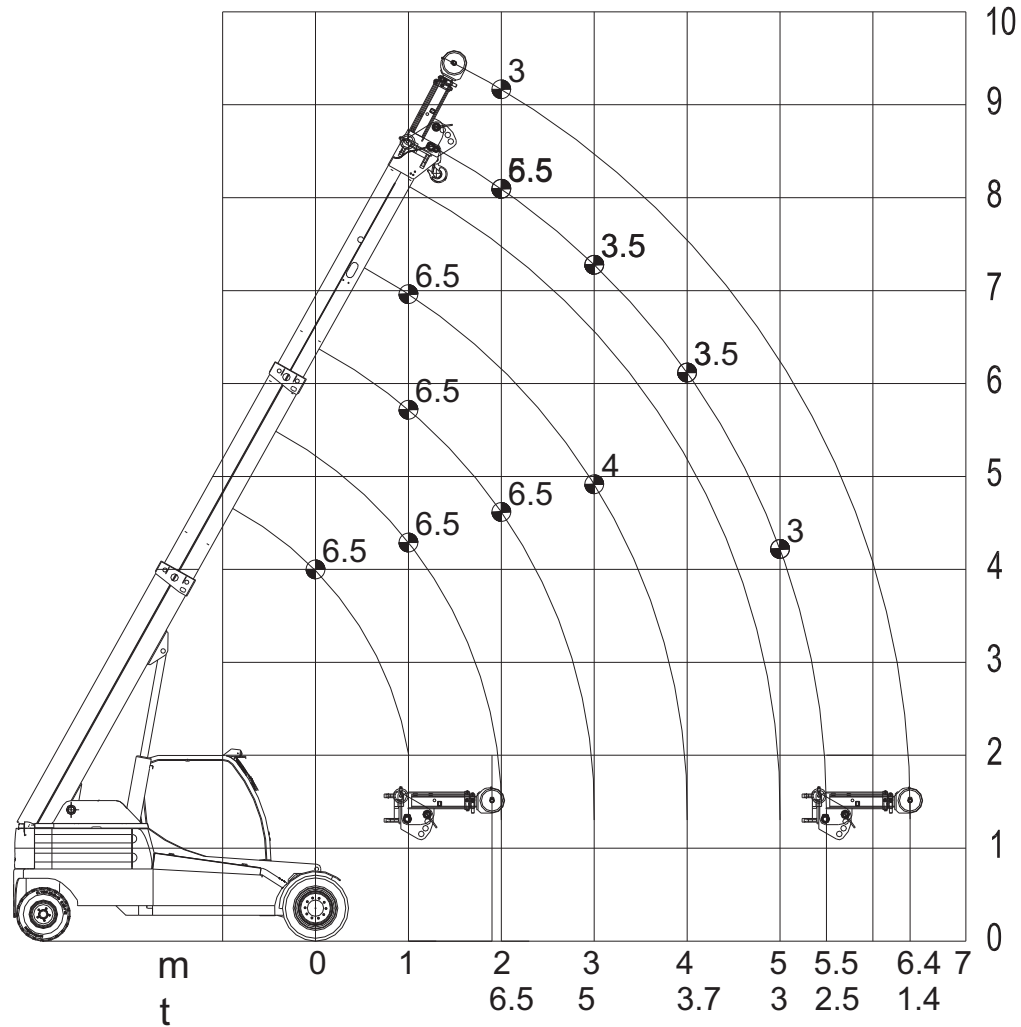

**DIAGRAMMA PORTATE GF100  
FALCONCINO PRIMA SEZ. ESTESA  
MAX 5.500 kg MODO OPERATIVO 2 - M2**

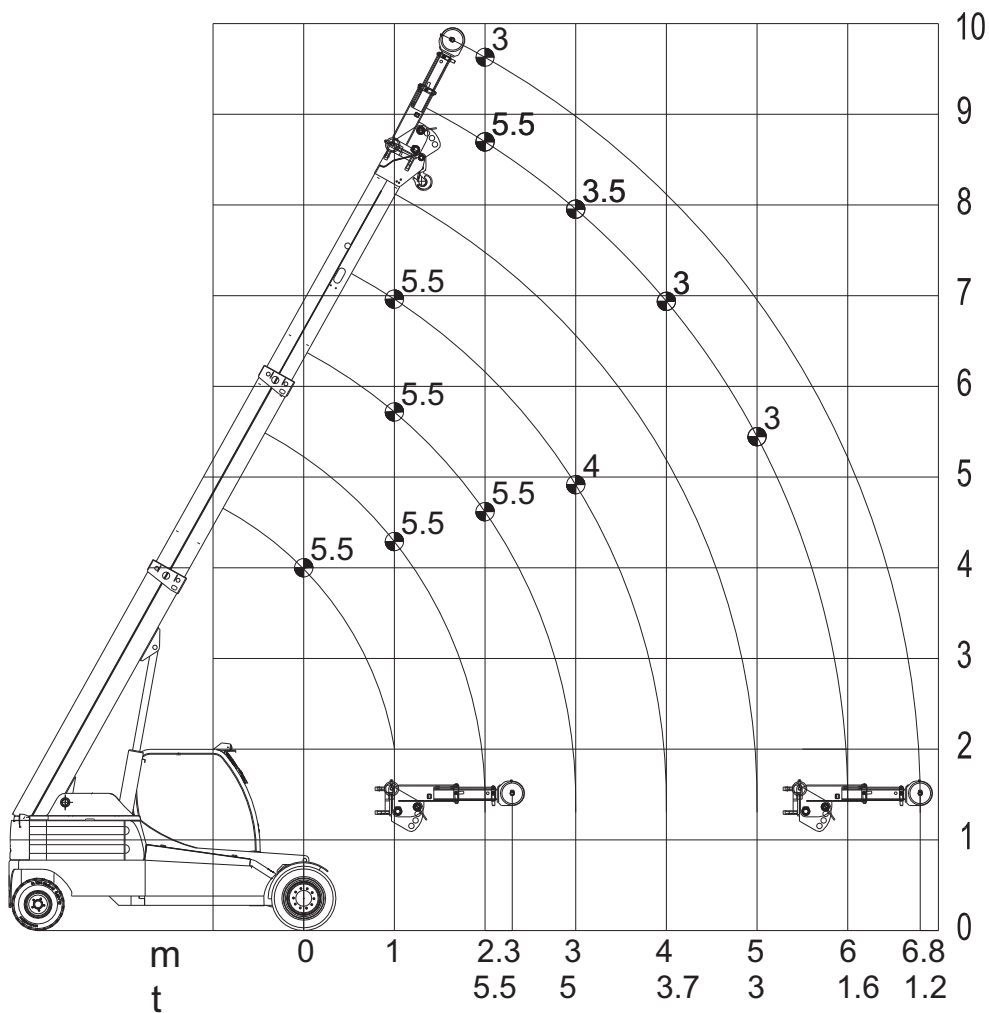

**DIAGRAMMA PORTATE GF100  
FALCONCINO 2 SEZ. ESTESE  
MAX 4.000 kg MODO OPERATIVO 3 - M3**

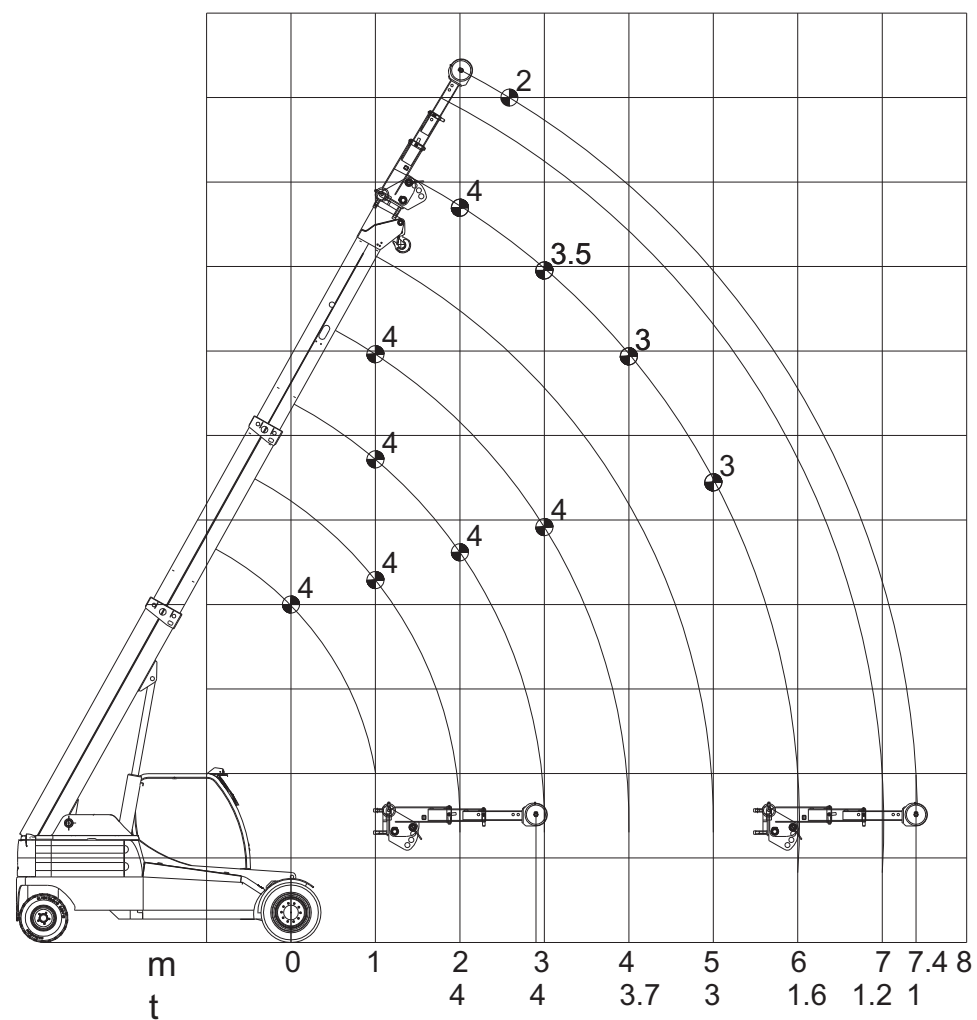

**DIAGRAMMA PORTATE GF100  
FALCONCINO CHIUSO 2 TAGLIE  
MAX 6.000 kg MODO OPERATIVO 4 - M4**

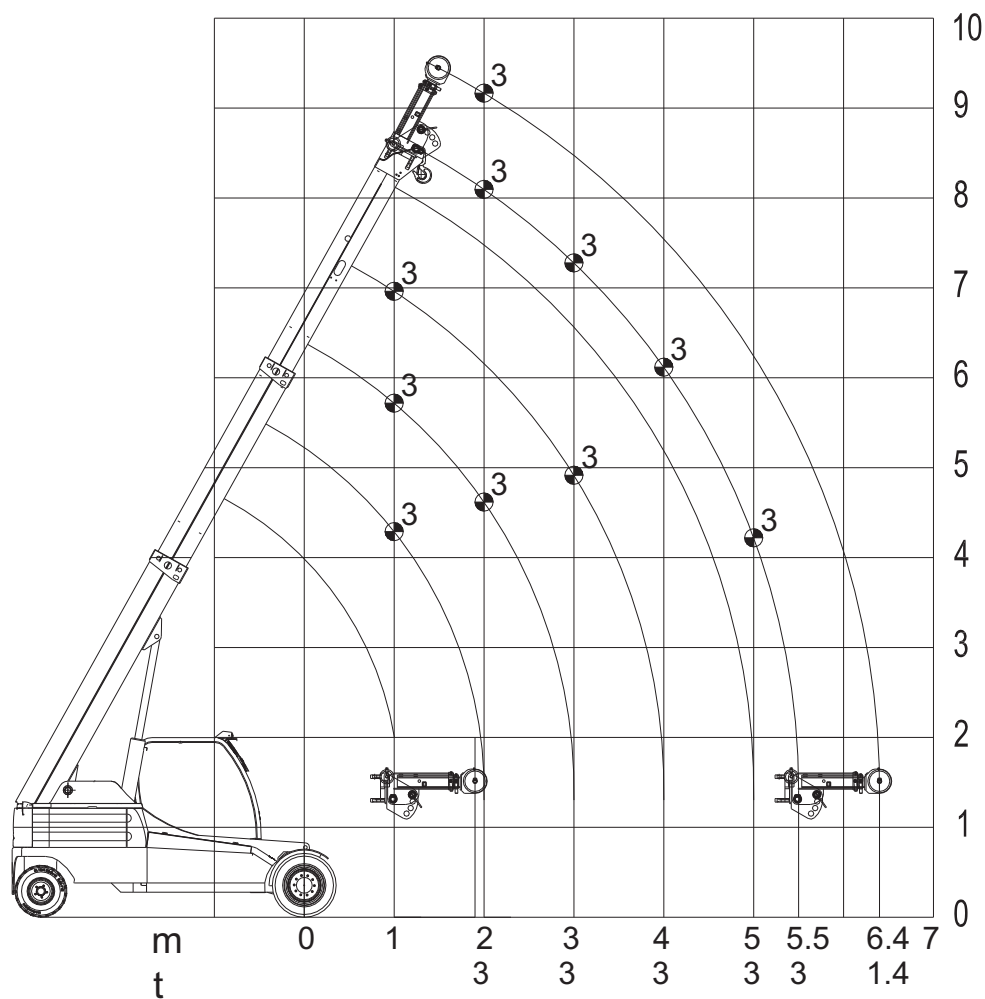

**DIAGRAMMA PORTATE GF100  
FALCONCINO CHIUSO 2 TAGLIA  
MAX 2.000 kg MODO OPERATIVO 5 - M5**

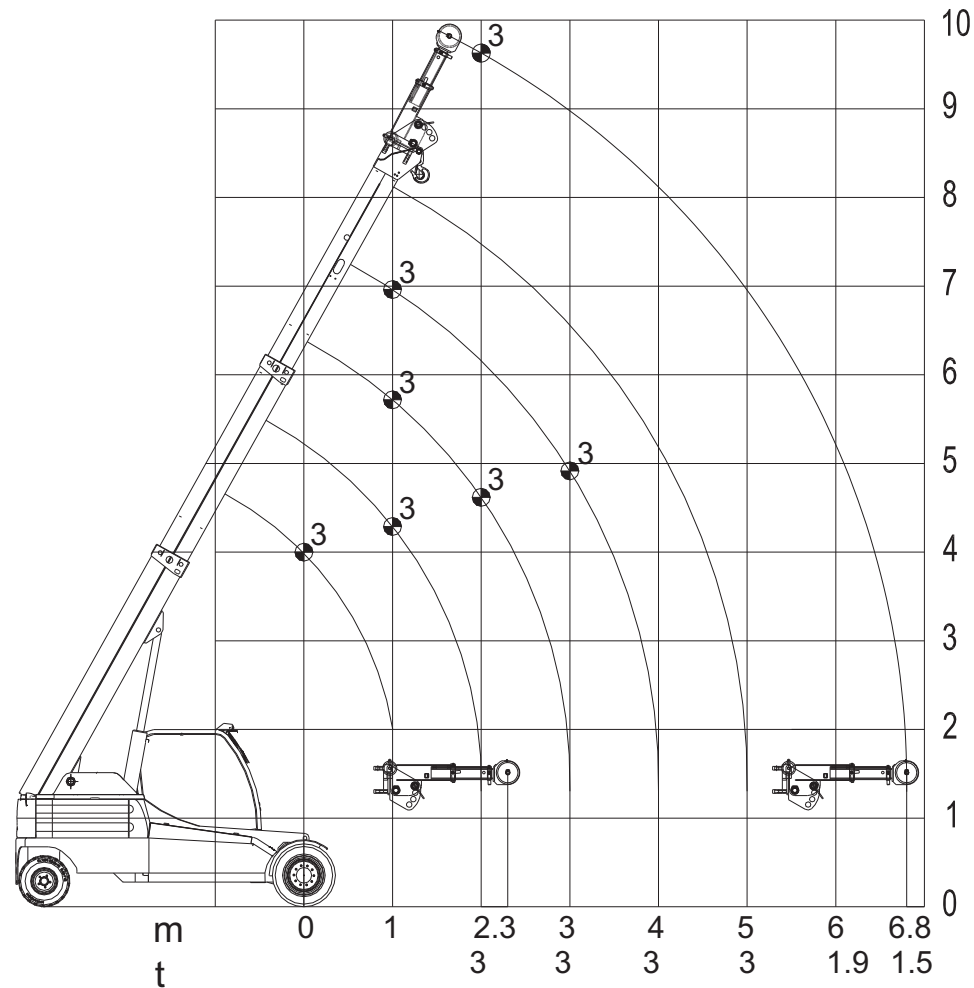

**DIAGRAMMA PORTATE GF100  
FALCONCINO PRIMA SEZ. ESTESA 2 TAGLIE  
MAX 3.000 kg MODO OPERATIVO 6 - M6**

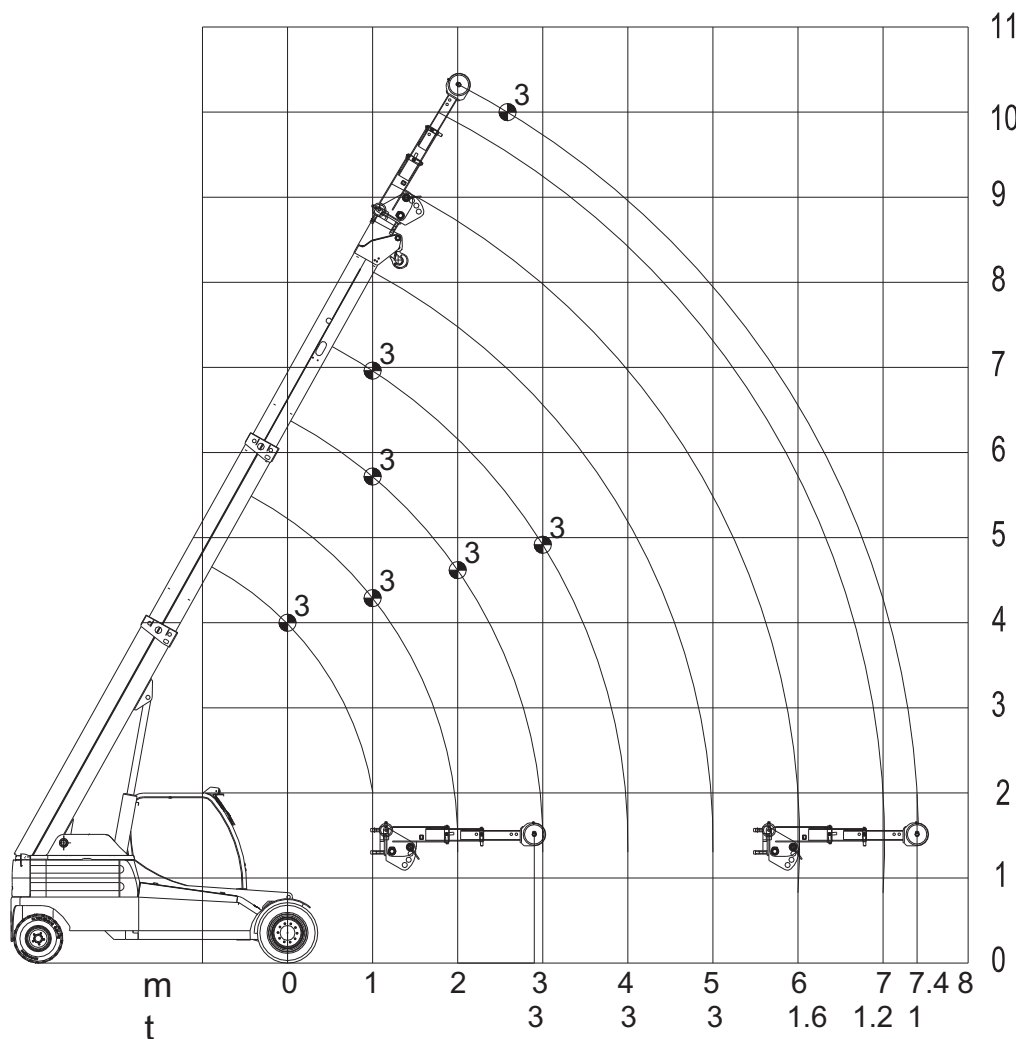

**DIAGRAMMA PORTATE GF100  
FORCA MAX 5 t  
MODO OPERATIVO 7 - M7**

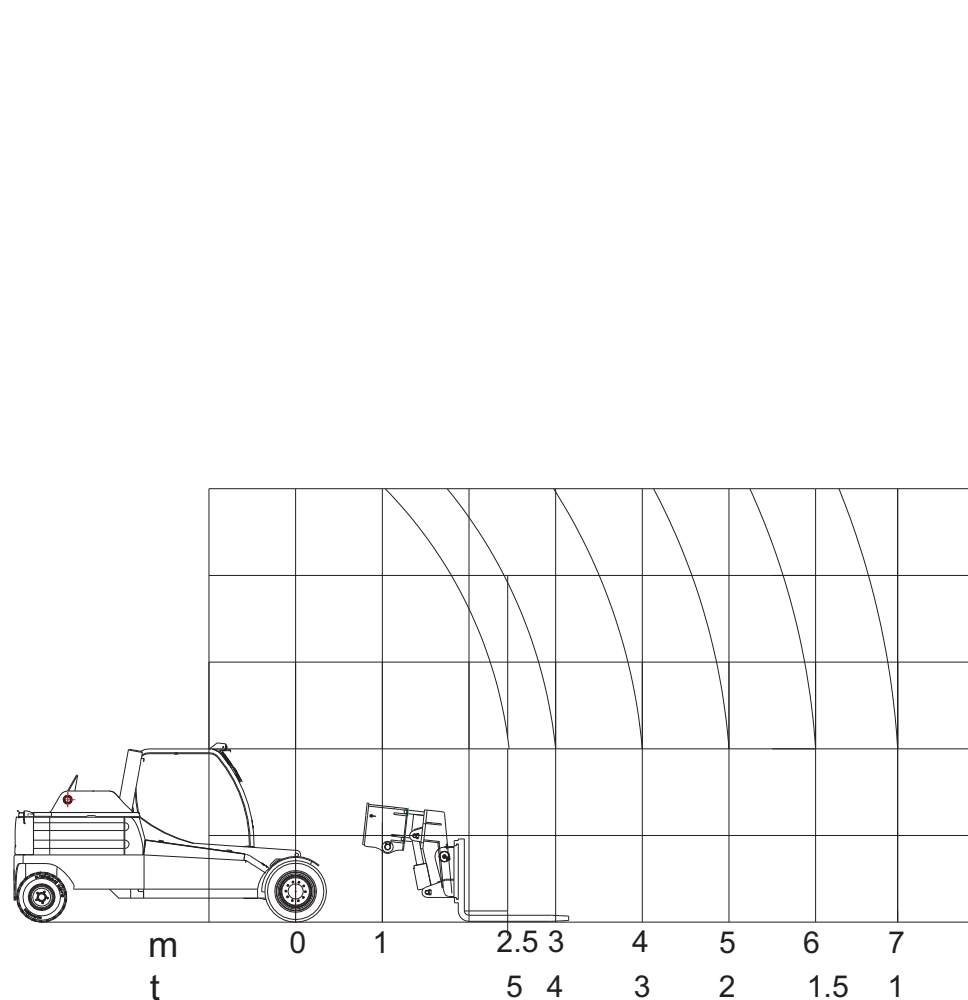

# GALIZIA GF100 2017 M1

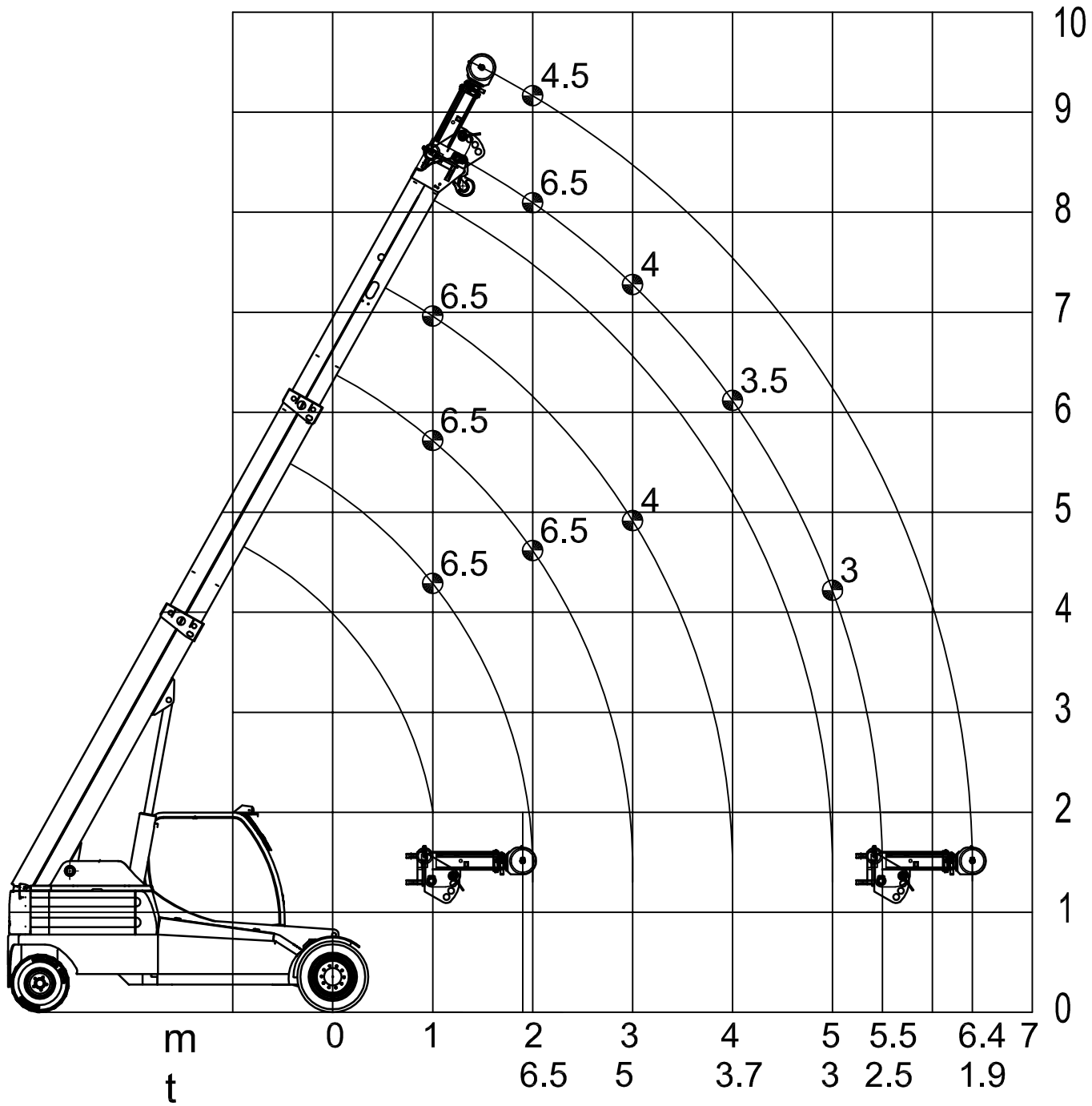

# GALIZIA GF100 2017 M2

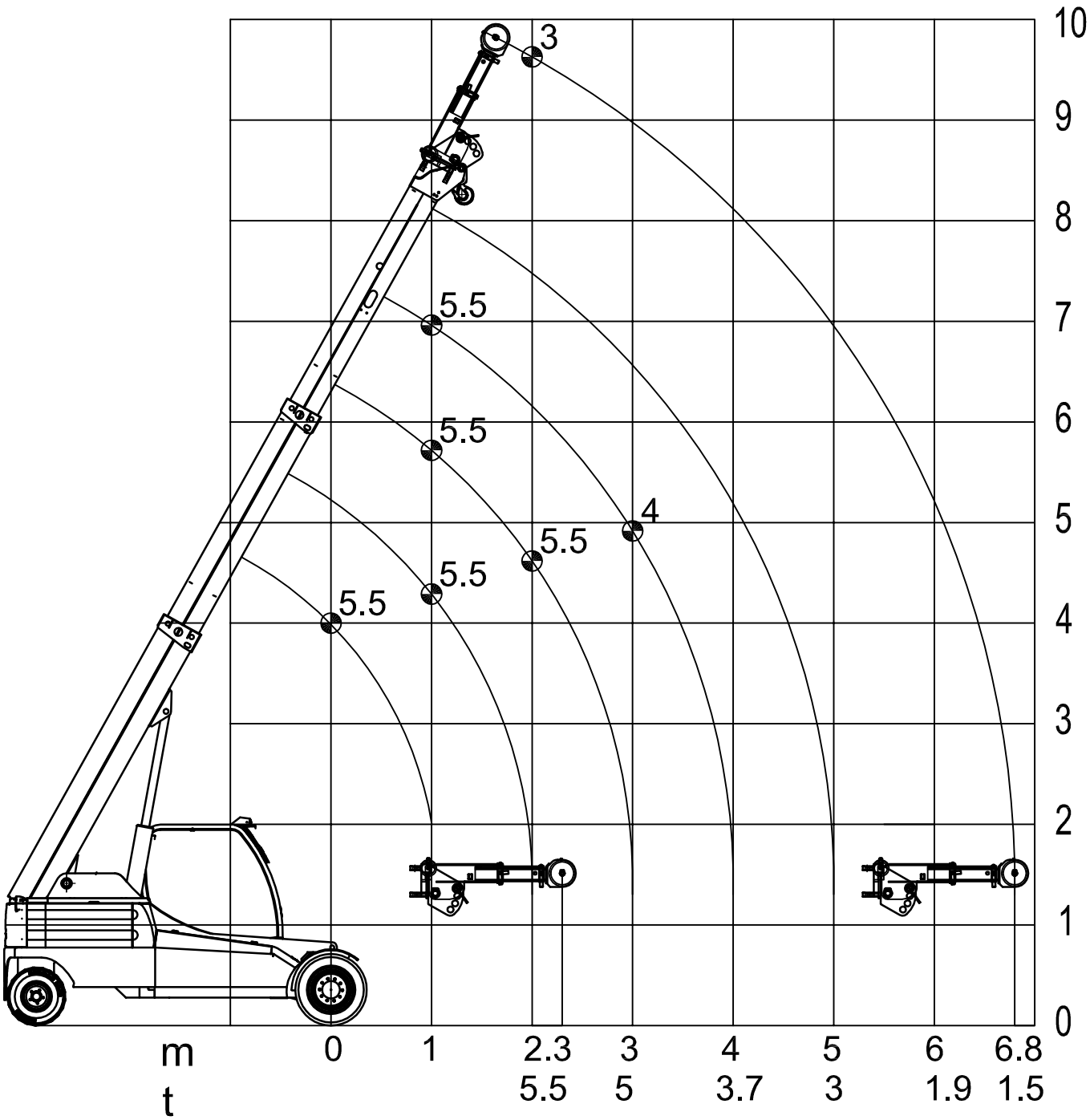



# GALIZIA GF100 2017 M3

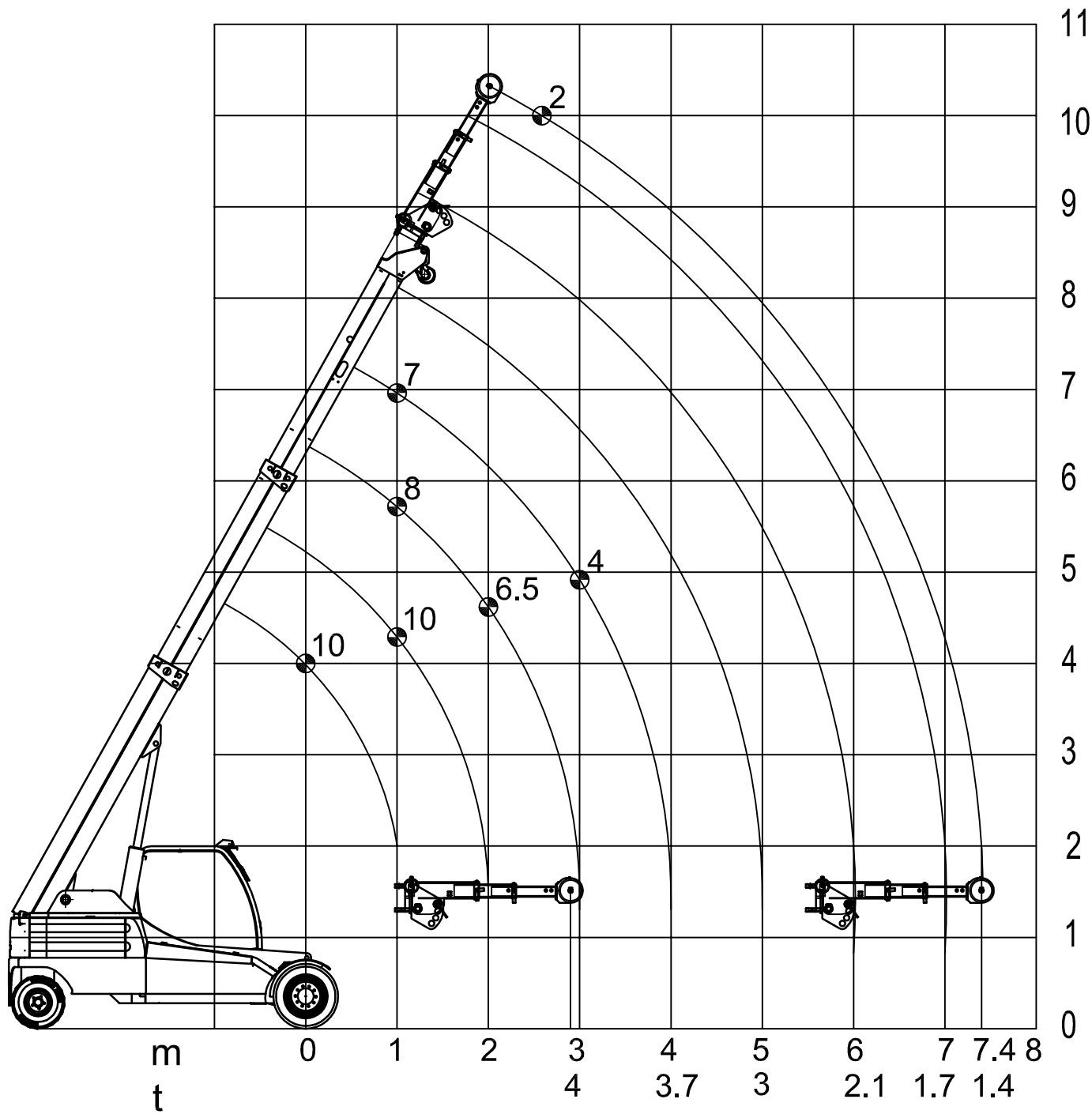

# GALIZIA GF100 2017

